



Installation Instruction Electric Heat Exchanger

Electric/Swimming Pool Water
EWT 80-40/-41
EWT 80-70/-71
EWT 80-81

Your **BEHNCKE®**-Specialist Dealer



Dear customer,

congratulations on purchasing your new, state-of-the-art electric heat exchanger „Made in Germany“.

BEHNCKE[®] GmbH has produced high-quality products for the public and private swimming pool and whirlpool sector for more than 30 years.

Your **BEHNCKE**[®] specialist dealer will always give you advice and support.

Please read this installation instruction with great care.

Store the installation instruction for future use.

Subject to technical alteration!

Table of contents

1 Safety	34
1.1 Risks When Handling Electric Heat Exchanger	34
1.2 Safety Instructions and Information	34
1.3 Intended Use	35
1.4 Sources of Danger	35
1.5 Safety Measures on the Installation Site	36
1.6 Safety Equipment	37
2 Technical Data	38
2.1 EWT 80-40* – Sleeve for Tube and Thread 11/2	38
2.2 EWT 80-41* – Sleeve for Tube and Thread 11/2	38
2.3 EWT 80-70* – PVC Glued/Screwed Connection	38
2.4 EWT 80-71* – PVC Glued/Screwed Connection	39
2.5 EWT 80-81* – PVC Glued/Screwed Connection	39
3 Set-up/Installation	40
3.1 Transportation/Storage	40
3.2 Set-up and Installation Dimensions	40
3.3 Set-up	40
3.4 Installation	44
3.5 Water Connection	44
3.6 Electrical Connections	47
4 Functional Course	48
5 Initial Operation	48
6 Maintenance/Repair	48
6.1 Hibernation of the EWT in Frost-proof Rooms	49
6.2 Hibernation of the EWT in Non Frost-proof Rooms	49
7 Troubleshooting	49
8 Circuit Diagram	50
8.1 Switchbox for EWT 80-41/-71/-81	50
9 Explosion Drawings and Piece Lists	52
9.1 Piece List EWT 80-40/-41/-70/-71/-81	57
10 Declaration of Conformity	58

1 Safety

1.1 Risks When Handling Electric Heat Exchanger

The electric heat exchanger has been built on the basis of state-of-the-art technology and the approved safety-technical guidelines. Nevertheless, risks might occur during use such as

- violation of operator or
- third parties
- impairments in electric heat exchanger or
- damage to other material values.

All persons, who are engaged in installation, initial operation, operation, maintenance and repair of the electric heat exchanger, have to:

- be qualified accordingly.
- strictly observe these installation instructions.

„This appliance is not intended for use by persons (including children) with reduced physical, sensory or mental capabilities, or lack of experience and knowledge, unless they have been given supervision or instruction concerning use of the appliance by a person responsible for their safety. Children should be supervised to ensure that they do not play with the appliance.“

The electric heat exchanger may only be used

- for the intended purpose.
- in a perfect safety-technical state.

In the case of disorders, which might impair safety, a sanitary expert is to be consulted.

In rooms where electrical appliances are in function should be a smoke detector installed.

It is your safety!!

1.2 Safety Instructions and Information

The following symbols are used in this safety instruction:



This symbol means **warning of dangerous electric high power** to the health of persons.

Non-observance of this information might lead to severe injury.



danger

This symbol means **possible danger** to the health of persons.

Non-observance of this information might lead to severe injury.



This symbol means a **possible hazard** for the health of persons.
*Non-observance of this information might lead to injury to persons.
 or damage to things.*



This symbol gives **important information** for correct handling of the system.
*Non-observance of this information might lead to disorders in the system or the
 environment.*

1.3 Intended Use

The electric heat exchanger is exclusively designed for heating bathwater with activated recirculating or filter pump.

Any other mode of application is not regarded as intended use. The manufacturer **BEHNCKE**[®] GmbH is not liable for any resulting damage. Other uses are only possible upon agreement with and approval by the manufacturer.

Important!



The intended use also includes
 – observance of all pieces of information in the installation instructions and
 – execution of inspection and maintenance activities.

Maximum permissible operational overpressure of 300 kPa (3 bar) must not be exceeded. Minimum permissible operational overpressure of 10 kPa (0.1 bar) must be achieved.

The minimum throughput is 1000l/h.

Water with the following values may only be used

EWT 80-40/-41/-70/-71

Chloride content	max. 500 mg/l
Free chlorine	max. 1.3 mg/l
	pH value 6,8 – 8,2

**The specific water resistance may
 not be $\leq 1100 \Omega \text{ cm}$ bei 15°C.**

EWT-81

Chloride content	max. 3000 mg/l
Free chlorine	unlimited
	pH value 6,8 – 8,2
salt content	max. 3,5%

Retrofits and changes in the heat exchanger are prohibited for safety reasons. For safety reasons, maintenance and repair activities in piping and electrical installation are only to be executed by specialist personnel

1.4 Sources of Danger



The electric heat exchanger can be damaged.

If the maximum operational pressure of 300 kPa (3.0 bar) is exceeded, the electric heat exchanger might develop leaks.

The risk of burns exists.



The connections and the electric heat exchanger might reach temperatures of up to 100° C.

In the case of a failure of the safety devices (safety pressure limiter and/or safety temperature limiter and/or flow control) strong overheating of the electric heat exchanger is possible.

The installation of a flow control as an additional safety device is recommended. (see EWT 80-41/-71/-81)

It prevents the heating resistor from burning out during water standstill.

If the electric heat exchanger is installed more than 0.5 m below the surface of the bathwater, the safety pressure limiter becomes ineffective.

The installation of a flow control is prescribed in this case as an additional safety device.



The electric heat exchanger might be damaged.

If dripping water falls onto the outer skin or if metal particles enter the electric heat exchanger, the risk of contact corrosion exists.

1.5 Safety Measures on the Installation Site

The electric heat exchanger is to be installed in a frost-proof room with a mounting device made of plastic or stainless steel.

Please ensure that the maximum operational overpressure of 300 kPa (3.0 bar) is not exceeded.



The electric heat exchanger or the environment can be damaged.

Please check the electric heat exchanger and its connections for tightness and visible damage once a week during operation.



The danger of combustion exists.

In the case of a failure of the safety pressure limiter and the safety temperature limiter, strong overheating of the electric heat exchanger is possible.

Do not store any combustible materials in the environment.

The installation of a flow control as an additional safety device is recommended. (see EWT 80-41/-71/-81) It prevents the heating resistor from burning through during a water standstill.



The electric heat exchanger can be damaged.

The electric heat exchanger may only be put into operation if it has been ensured that the electric heat exchanger is continuously supplied with water during operation. The water throughput must be at least 1000l/hour.

1.6 Safety Equipment

The warning sign on the electric heat exchanger refers to the dangers due to electric current.

The electric heat exchanger is equipped with a safety pressure limiter. The safety pressure limiter serves as a low-water safeguarding device. (see EWT 80-40 and -70) The electric heat exchanger must be protected by at least two safety circuit breakers.



The following combinations are offered by the factory

- with a control thermostat.
- with a control thermostat and a safety temperature limiter (STB).
- with a control thermostat, a STB and a Flow switch.
- with a contactor of up to 12 kW.

If no contactor has been installed by the factory, an external protection for switching the heating element is necessary (e. g. Behncke control for EWT 80-xx).

Switchbox with contactor:	3–12 kW Article No. 304.006.12
	15–18 kW Article No. 304.006.18

Controller including second contactor to facilitate emergency off including Indicator light (highly recommended) for EWT 80-41/-71/-81 with a control thermostat and STB:	3–12 kW Article No. 304.007.12
	15–18 kW Article No. 304.007.18

- The switchbox is not included in the shipment – (and should be ordered separately).

The safety devices switch off the electric heat exchanger if impermissible values are reached.

2 Technical Data

2.1 EWT 80-40* – Sleeve for Tube and Thread 1 1/2”

Article	Power in kW	Supply Voltage in Volt	Temperature Selection in °C	Article No.
EWT 80-40	1,5	230	0 - 40	304.501.50
EWT 80-40	3	400	0 - 40	304.503.00
EWT 80-40	6	400	0 - 40	304.506.00
EWT 80-40	9	400	0 - 40	304.509.00
EWT 80-40	12	400	0 - 40	304.512.00
EWT 80-40	15	400	0 - 40	304.515.00
EWT 80-40	18	400	0 - 40	304.518.00

2.2 EWT 80-41* – Sleeve for Tube and Thread 1 1/2” with flow switch

Article	Power in kW	Supply Voltage in Volt	Temperature Selection in °C	Article No.
EWT 80-41	1,5	230	0 - 40	304.401.50
EWT 80-41	3	400	0 - 40	304.403.00
EWT 80-41	6	400	0 - 40	304.406.00
EWT 80-41	9	400	0 - 40	304.409.00
EWT 80-41	12	400	0 - 40	304.412.00
EWT 80-41	15	400	0 - 40	304.415.00
EWT 80-41	18	400	0 - 40	304.418.00

2.3 EWT 80-70* – PVC Glued/Screwed Connection

Article	Power in kW	Supply Voltage in Volt	Temperature Selection in °C	Article No.
EWT 80-70	1,5	230	0 - 40	304.501.57
EWT 80-70	3	400	0 - 40	304.503.07
EWT 80-70	6	400	0 - 40	304.506.07
EWT 80-70	9	400	0 - 40	304.509.07
EWT 80-70	12	400	0 - 40	304.512.07
EWT 80-70	15	400	0 - 40	304.515.07
EWT 80-70	18	400	0 - 40	304.518.07

* Subject to changer or special design.

Technical Data

2.4 EWT 80-71* – PVC Glued/Screwed Connection with flow switch

Article	Power in kW	Supply Voltage in Volt	Temperature Selection in °C	Article No.
EWT 80-71	1,5	230	0 - 40	304.401.57
EWT 80-71	3	400	0 - 40	304.403.07
EWT 80-71	6	400	0 - 40	304.406.07
EWT 80-71	9	400	0 - 40	304.409.07
EWT 80-71	12	400	0 - 40	304.412.07
EWT 80-71	15	400	0 - 40	304.415.07
EWT 80-71	18	400	0 - 40	304.418.07

2.5 EWT 80-81* – PVC Glued/Screwed Connection with integrated flow switch

Article	Power in kW	Supply Voltage in Volt	Temperature Selection in °C	Article No.
EWT 80-81	1,5	230	0 - 40	304.302.99
EWT 80-81	3	400	0 - 40	304.303.00
EWT 80-81	6	400	0 - 40	304.306.00
EWT 80-81	9	400	0 - 40	304.309.00
EWT 80-81	12	400	0 - 40	304.312.00
EWT 80-81	15	400	0 - 40	304.315.00
EWT 80-81	18	400	0 - 40	304.318.00

* Subject to changer or special design.

3 Set-up/Installation

3.1 Transportation/Storage

Transport the electric heat exchanger only after it has been drained.

Store the flushed and drained electric heat exchanger in interior rooms with non-aggressive atmosphere only.

3.2 Set-up and Installation Dimensions

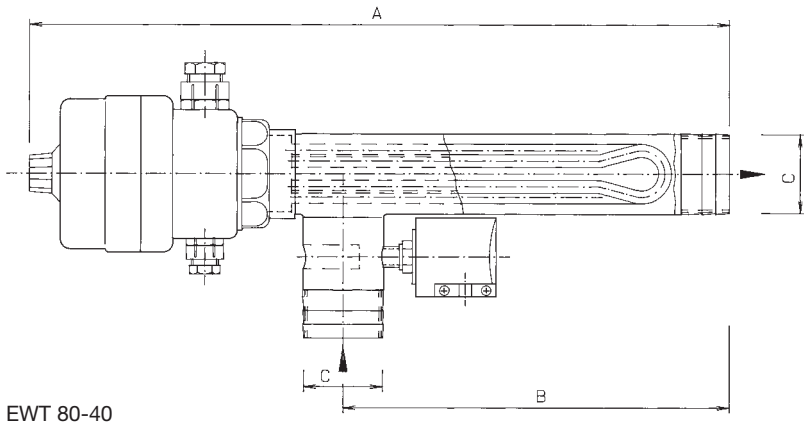

Article	kW	A mm	B mm	C* Ø Inches
EWT 80-40	1,5	330	130	1½
EWT 80-40	3	440	240	1½
EWT 80-40	6	510	310	1½
EWT 80-40	9	510	310	1½
EWT 80-40	12	600	400	1½
EWT 80-40	15	800	600	1½
EWT 80-40	18	800	600	1½

* Sleeve for turbe and thread

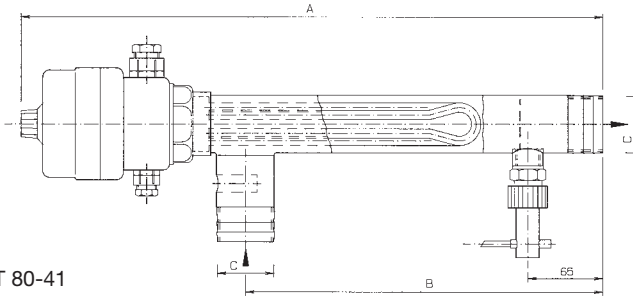

EWT 80-41

Article	kW	A mm	B mm	C* Ø Inches
EWT 80-41	1,5	400	200	1½
EWT 80-41	3	510	310	1½
EWT 80-41	6	580	380	1½
EWT 80-41	9	580	380	1½
EWT 80-41	12	670	470	1½
EWT 80-41	15	870	670	1½
EWT 80-41	18	870	670	1½

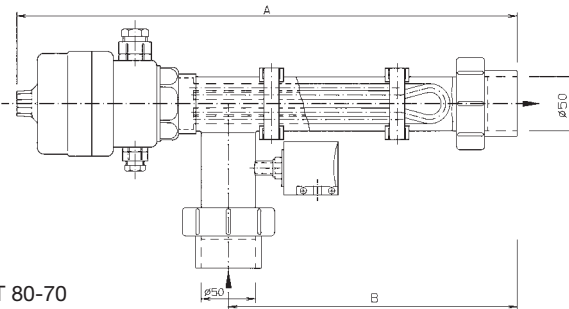

EWT 80-70

Article	kW	A mm	B mm
EWT 80-70	1,5	380	180
EWT 80-70	3	490	290
EWT 80-70	6	560	360
EWT 80-70	9	560	360
EWT 80-70	12	650	450
EWT 80-70	15	850	650
EWT 80-70	18	850	650

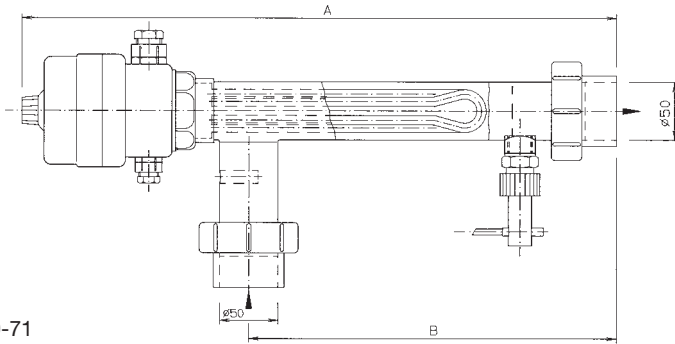

EWT 80-71

Article	kW	A mm	B mm
EWT 80-71	1,5	450	250
EWT 80-71	3	560	360
EWT 80-71	6	630	430
EWT 80-71	9	630	430
EWT 80-71	12	720	520
EWT 80-71	15	920	720
EWT 80-71	18	920	720

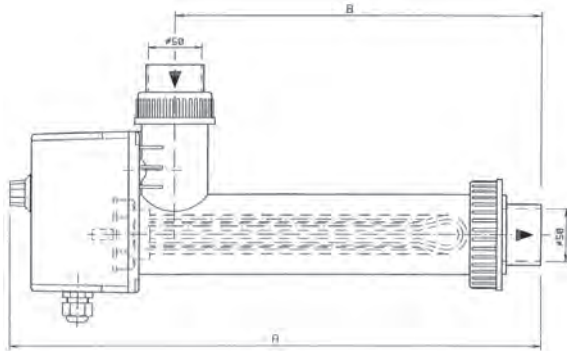

EWT 80-81

Article	kW	A mm	B mm
EWT 80-81	1,5	495	340
EWT 80-81	3	495	340
EWT 80-81	6	495	340
EWT 80-81	9	495	340
EWT 80-81	12	775	620
EWT 80-81	15	775	620
EWT 80-81	18	775	620

3.3 Set-up

Set up the electric heat exchanger in frost-proof and dry rooms with non-aggressive atmosphere only. Dripping water might damage the electric heat exchanger.

Ensure easy access for installation and removal purposes.

The following water values are always to be observed for the electric heat exchanger.



EWT 80-40/-41/-70/-71

Chloride contents	max. up to 500 mg/l
Free chlorine	max. up to 1.3 mg/l
pH Value	6,8 to 8,2

EWT 80/-81

Chloride contents	max. up to 3000 mg/l
Free chlorine	unlimited
pH Value	6,8 to 8,2
salt contents	max. 3,5%

The specific water resistance may not be $\leq 1100 \Omega \text{ cm}$ bei 15°C liegen.

Water throughput	min. 1000 l/h
Minimum operational overpressure	10 kPa (0,1 bar)
Maximum operational overpressure	300 kPa (3 bar)



The risk of combustion exists in the case of a failure of the safety devices.

Overheating of the electric heat exchanger might cause a fire.

Draining of the electric heat exchanger during operation must be prevented. Do not store any combustible material in the environment.

3.4 Installation

Check the electric heat exchanger before installation for visible damage.

The electric heat exchanger can be installed horizontally or vertically above or below water level.

When installed either 0,5 m above or below the water-level the manometric safety switch (low-water safety device) loses its effectiveness. In this event, instead of a manometric switch, it is absolutely necessary to fit a **BEHNCKE**® flow switch (see EWT 80-41/-71/-81).

3.5 Water Connection

3.5.1 Installation Layout Above the Water Level

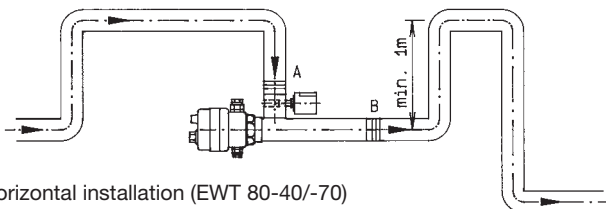

Figure: horizontal installation (EWT 80-40/-70)

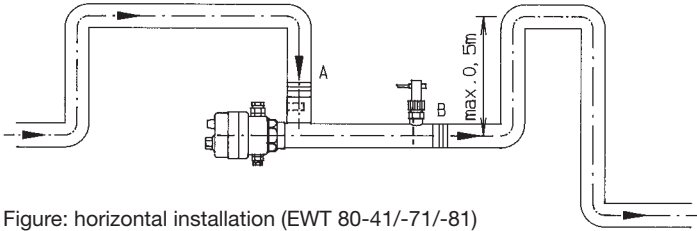

Figure: horizontal installation (EWT 80-41/-71/-81)

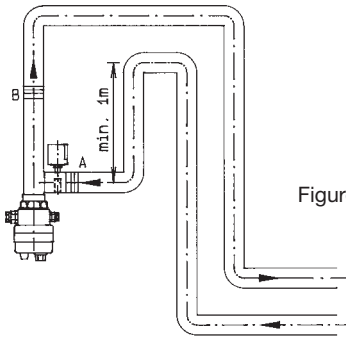

Figure: vertical installation (EWT 80-40/-70)

3.5.2 Installation Layout Below the Water Level

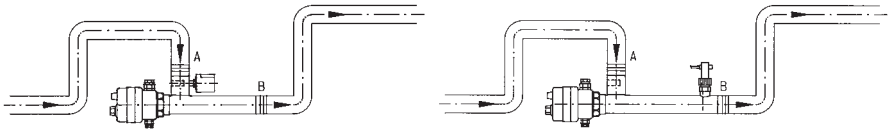

Figure: horizontal installation EWT 80-40/-70 Figure: horizontal installation EWT 80-41/-71/-81

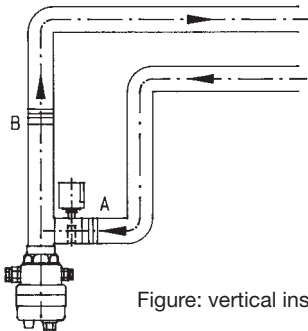

Figure: vertical installation EWT 80-40/-70

3.5.3 Connecting the Electric Heat Exchanger to the Water Cycle of a Filter System

Install the electric heat exchanger in the pressure line (to the basin) after pump and filter.

The EWT 80-40/-41 is integrated into the water cycle via interior threads or tube connections with tube clips.

The EWT 80-70/-71 EWT-81 is integrated into the water cycle with PVC glued/screwed connections.

The electric heat exchanger can be damaged.

When the heat exchanger is connected to the water cycle, please take care that metal particles do not enter the electric heat exchanger.

The electric heat exchanger might be damaged by chemicals.

Disinfecting devices are always to be installed in the flow direction after the electric heat exchanger. The minimum distance must be 1 m and the order: first water hardness control, than chlorine vaccination is to be observed. If chemicals (e. g. chlorine gas) are used, gases must not enter the electric heat exchanger during filter standstill times.



3.5.4 General Installation Instructions for Flow switch (without EWT 80-81)

At first clean the piping system where the flow switch should be installed and remove any magnetic particles such as weld spatters.

Straight pipe upstream and downstream of the flow switch must be at least 5 x pipe diameter.

The flow switch must only be installed in a horizontal pipe.

Contact the manufacturer for deviating positions.

Install the switch only vertically, max. deviation is 45° (fig. 1).

There is an arrow on the flow switch. Make absolutely sure that this arrow is parallel with the pipe axis and points into flow direction (fig. 2).

Make sure that there are no magnetic fields close to the flow switch. Such fields can affect the proper function of the instrument (fig. 2).

Screw on the union nut $\frac{3}{4}$ " made of plastic with a maximum torque of 8 Nm.

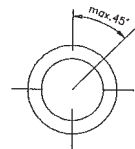

fig. 1

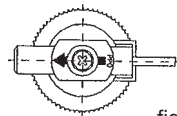

fig. 2

3.6 Electrical Connections



The connection can only be made by professionals. The rules according to VDE 0100 must be respected. The rules of the local EVU/RU must be respected. Outside of Germany are the countries own regulations.

The heat exchanger must be permanently connected to fixed pipework which is fitted with a protective earth conductor.

The electric heat exchanger must be protected by at least two safety circuit breakers.

The following combinations are offered by the factory

- with a control thermostat.
- with a control thermostat and a safety temperature limiter (STB).
- with a control thermostat, a STB and a Flow switch.
- with a contactor up to 12 kW.

If no contactor has been installed by the factory, an external protection for switching the heating element is necessary (e. g. Behncke control for EWT 80-xx).

Important!



It should be ensured that the electric heat exchanger can only be switched on if the water throughput is ensured.

The electrical connections are to be effected in accordance with the switch diagram.

For safety reasons, an FI safety switch is to be integrated into the voltage supply (30 mA). All metal parts are to be integrated into equipotential bonding.

3.6.1 Flow switch

Caution: Risk to life through electrical voltage!

Switch off the electrical system before you connect leads of the supply cable.

brown/black = connections for Reed contact (without 80-81)

The reed contact is electrically insulated (protection class II) and integrated into a plastic sleeve.

ATTENTION: The maximum electrical contact capacity indicated onto the type shield must not be exceeded, otherwise the reed contact, which is integrated in the switching unit, will be damaged. The switching capacity is reduced with inductive loads. Information about the protective system can be ordered at the manufacturer.

4 Functional Course

In the electric heat exchanger, heat is transferred to the bathwater through the heating element.

The thermostat regulates the water temperature in accordance with the adjusted value, range from 0 to 40°C.

EWT 80-40/-70: If the required operating overpressure falls to below 6 kPa (0.06 bar) due to insufficient water throughput, the safety pressure limiter switches off the electric heat exchanger.

EWT 80-41/-71/-81: If the required overpressure falls to below 36 l/min. due to insufficient water throughput, the Flow switch switches off the electric heat exchanger.

Special made with safety temperature limites: The safety temperature limiter protects from overheating. It switches the electric heat exchanger off at a temperature of 44°C.

By pressing the disorder button, the electric heat exchanger can be put into normal operation again after removal of the disorder.

5 Initial Operation

Have you read and understood these operating instructions - in particular chapter 1, Safety? Only then are you allowed to start the electric heat exchanger.

- Adjust the desired bathwater temperature in the thermostat.

The electric heat exchanger heats the bathwater as long as the adjusted temperature has not been reached,



The electric heat exchanger can be damaged.

Work in piping and electrical installation are only to be effected by specialist personnel for safety reasons.

Do not step on the heat exchanger.

Only carry out maintenance and repair work with closed blocking and control units in the water cycle.

- Ventilate the entire water cycle, otherwise can the heating element harm to take.

6 Maintenance/Repair

- Check the heat exchanger and its connections for their tightness once a week and ventilate the entire water cycle.



The electric heat exchanger can be damaged.

Work in the electrical heat exchanger are only to be effected by specialist personnel for safety reasons.

Do not step on the electric heat exchanger.

Only carry out work in the piping connections with closed blocking and control units in the water cycle!

6.1 Hibernation of the EWT in Frost-proof Rooms

Intervention in technical systems by unqualified persons might lead to injury or damage.

For hibernation in frost-proof rooms, the electric heat exchanger must be completely filled with water or be completely drained.

6.2 Hibernation of the EWT in Non Frost-proof Rooms



Expert hibernation without frost damage is possible if the following steps are observed:

- Close blocking units in the water cycle (the blocking units must be installed in frost-free rooms).
- Flush and drain electric heat exchanger and adjoining pipes until blocking units.

6.2.1 Electric Heat Exchanger with Vertical Layout

- Drain electric heat exchanger completely via drain fittings.

6.2.2 Electric Heat Exchanger with Horizontal Layout

- Remove heat exchanger with horizontal layout.
- Flush heat exchanger in order to remove contamination and store in a dry place.

7 Troubleshooting

Effects

No performance

Electric heat exchanger further heated up, despite deactivated bathwater recirculating pump

Checking the possible cause

is the electric heat exchanger connected to the electrical supply?

have the blocking units been opened?

is the electric heat exchanger completely filled with water?

has the electric heat exchanger been ventilated?

is there sufficient flow (see Technical Data) in the electric heat exchanger?

has the lock between bathwater pump and electric heat exchanger been activated?

8 Circuit Diagram

circuit diagram 1

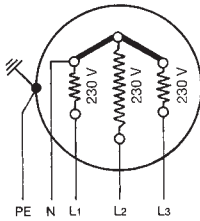

Y circuit
for 3 x 400 V (three-phase current)

circuit diagram 2

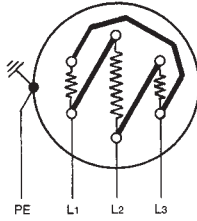

∅ circuit
for 3 x 230 V (three-phase current)

circuit diagram 3

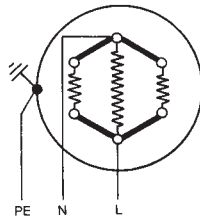

circuit up to a maximum of 6 kW
for 1 x 230 V (alternating current)

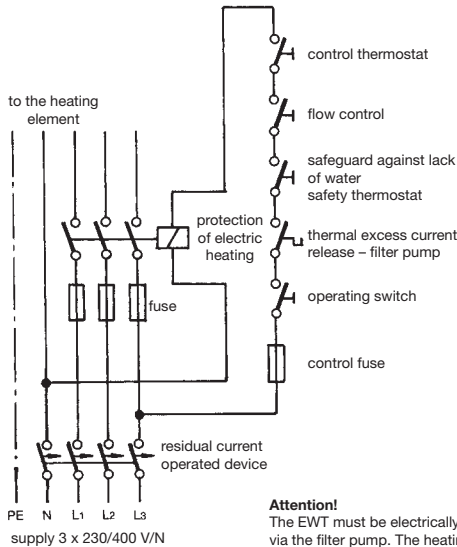

Attention!

The EWT must be electrically locked via the filter pump. The heating elements are wired in accordance with circuit diagram 1 by the factory.

8.1 Switchbox for EWT 80-41/-71/-81

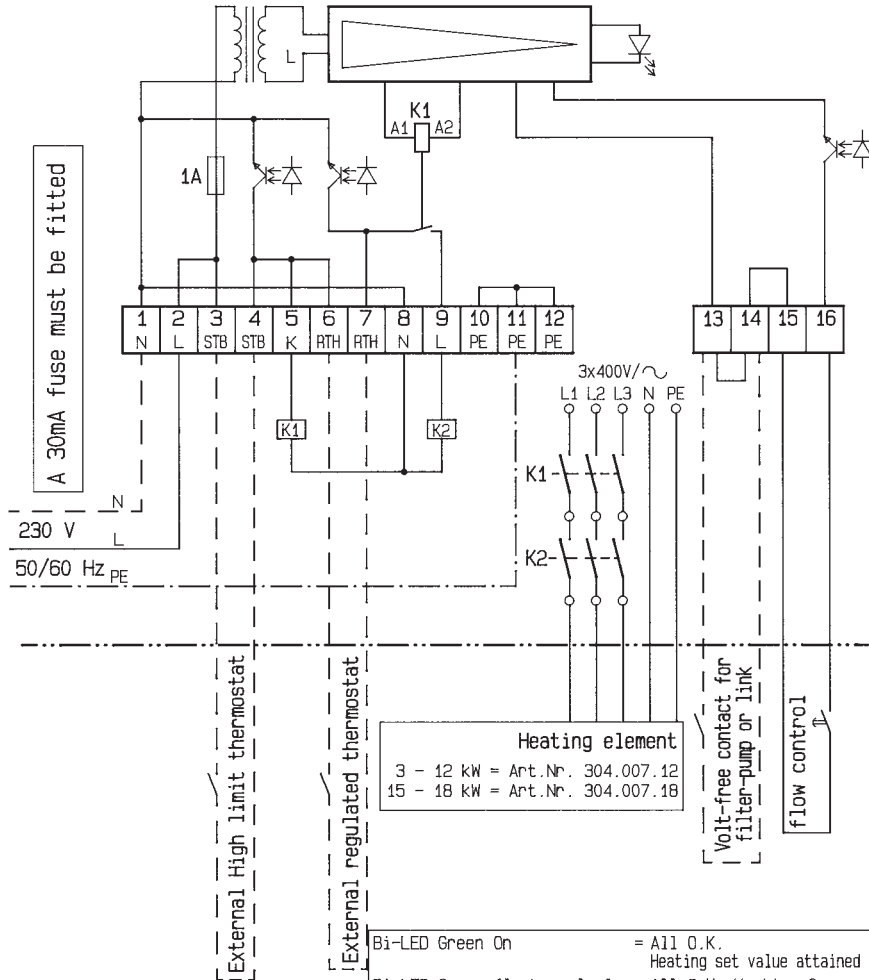

Attention: EWT 80-41/-71/-81 always with high limit thermostat order, otherwise no safety disconnection takes place.

Bi-LED Green On	= All O.K. Heating set value attained
Bi-LED Green flashes slowly	= All O.K. Heating On
Bi-LED Green flashes quickly	= 2 minute delay timer
Bi-LED Red On	= Temperature too high !
Bi-LED Red flashes slowly	= If more than 2 minutes, No Flow
Bi-LED Off	= No Mains Current or Flow Switch Off and set value temperature attained

English

9 Explosion Drawings and Piece Lists

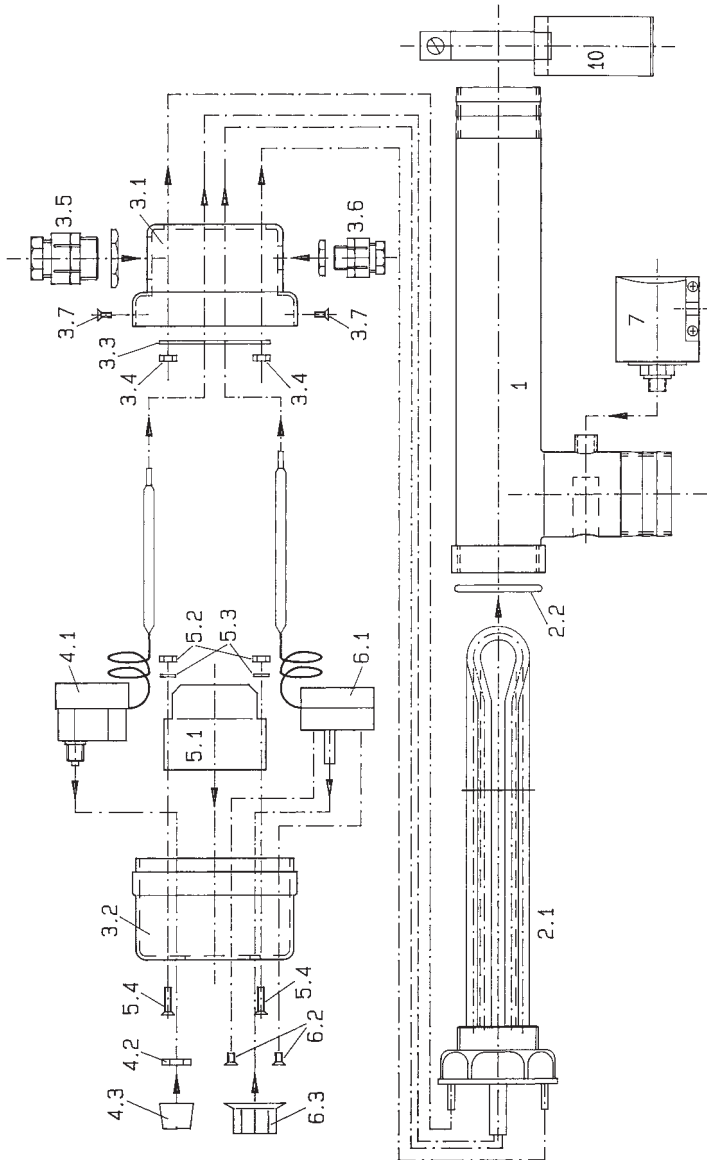

Figure: explosion drawing EWT 80-40

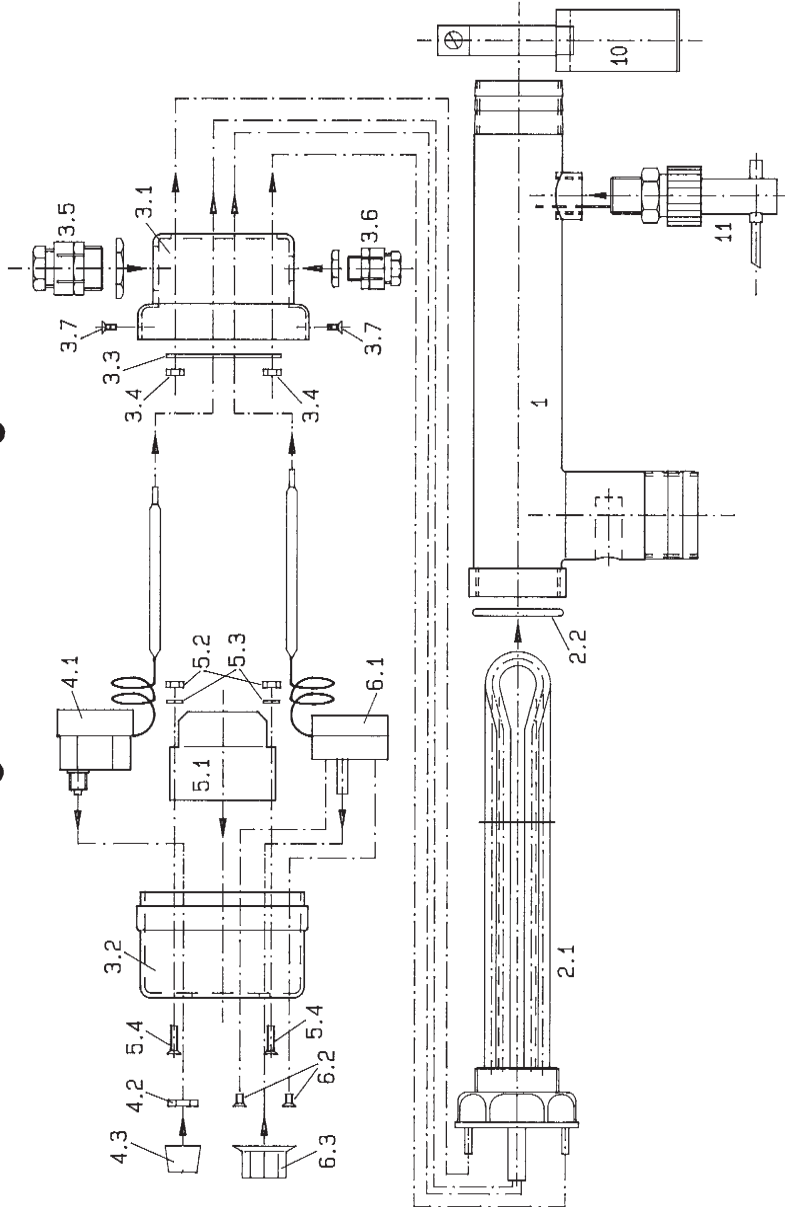
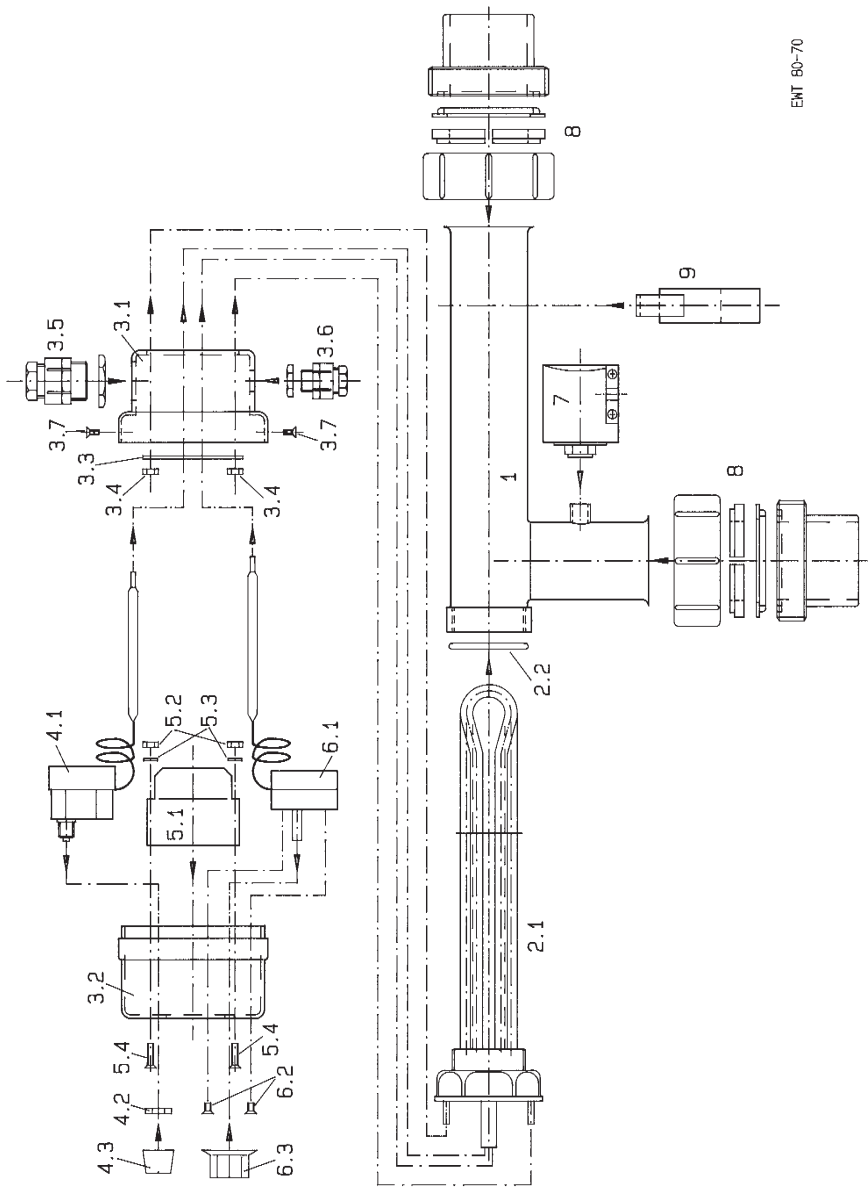

Figure: explosion drawing EWT 80-41



ENT 80-70

Figure: explosion drawing EWT 80-70

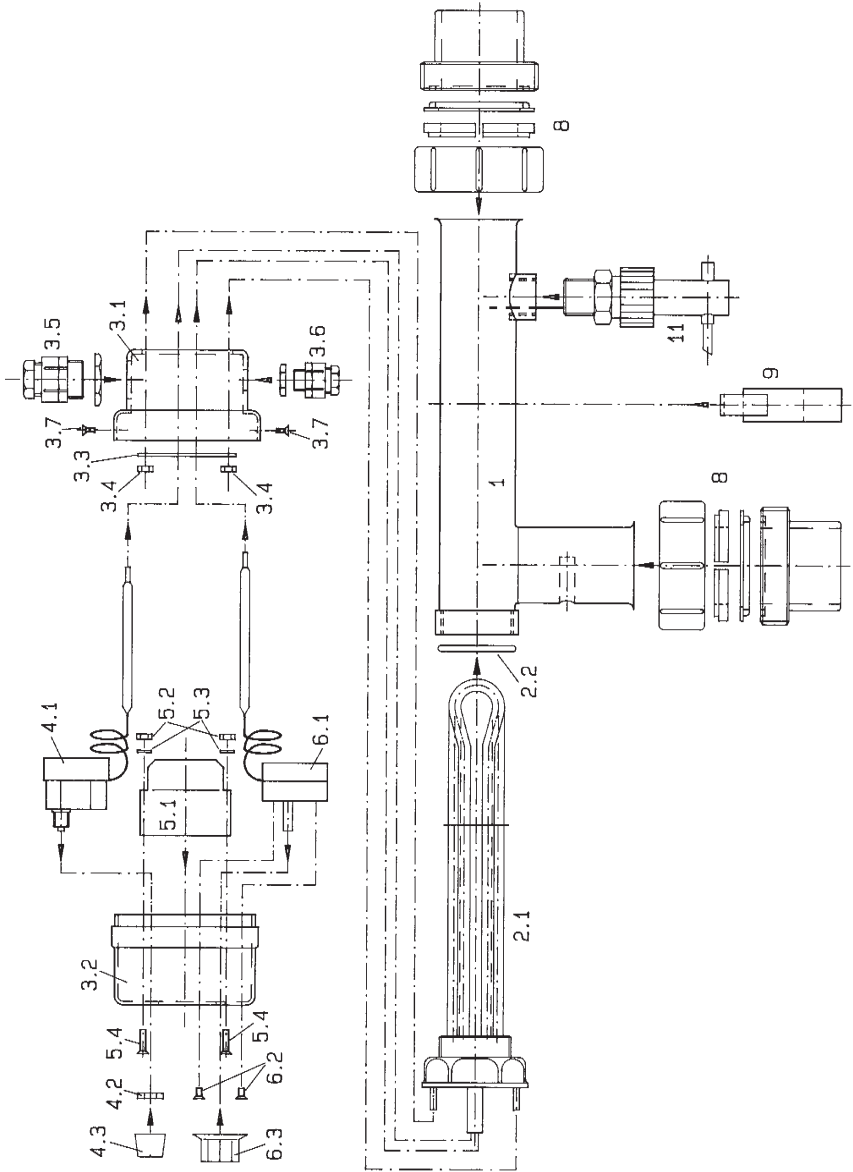

Figure: explosion drawing EWT 80-71

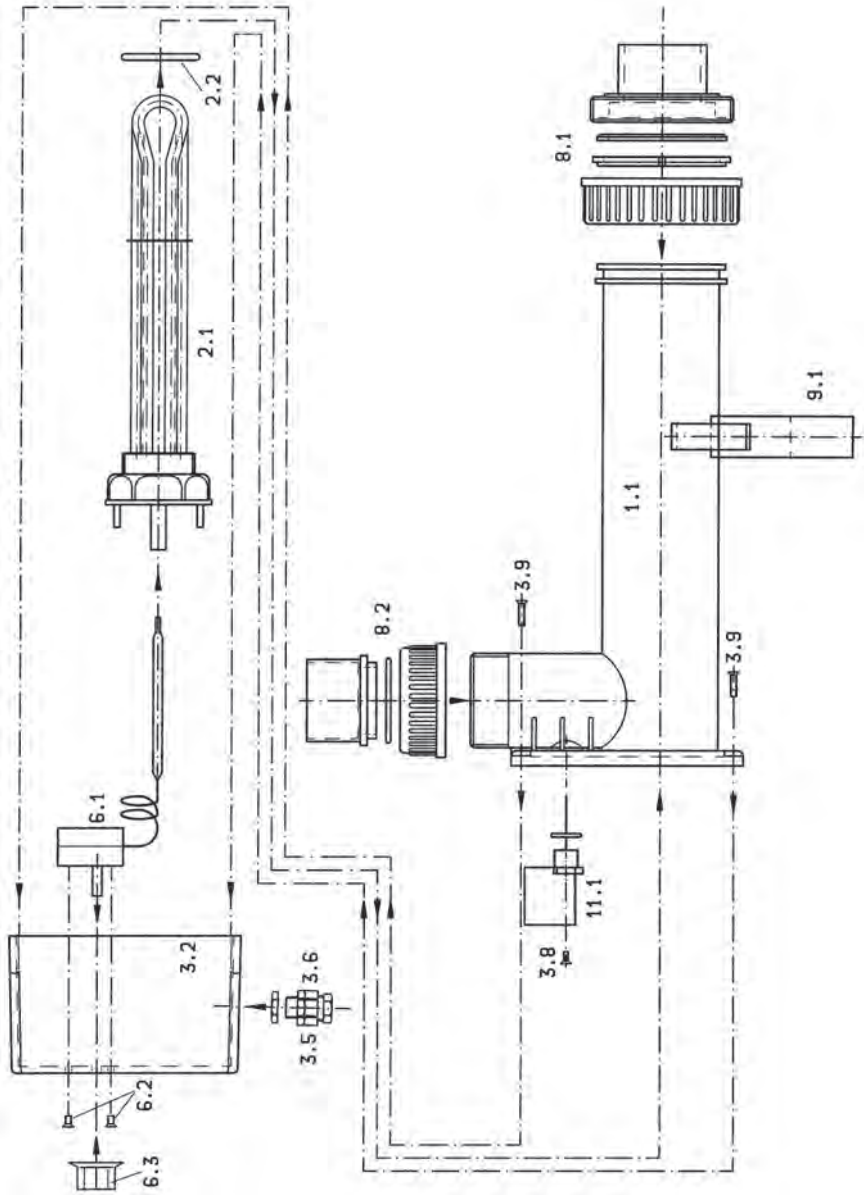

Figure: explosion drawing EWT 80-81

9.1 Piece List EWT 80-40/-41/-70/-71/-81

Item	Pcs.	Article Designation	Article No.
1	1	Housing, stainless steel 1.4571	–
1.1	1	Housing, plastic	–
2.1	1	Heating element, Incoloy 825 – 1,5/3/6/9/12/15/18 kW	304.024.01/02/03/04/05/06/07
2.2	1	O ring 44 x 4 NBR 75 Shore	–
3.1	1	PVC cap lower part	–
3.2	1	PVC cap upper part	–
3.3	1	Fastening ring, stainless steel	–
3.4	2	Nut M4	–
3.5	1	Screwed cable connection PG 13,5/16/21	–
3.6	1	Screwed cable connection PG 11	–
3.7	2	Sheet metal screw 2,9 x 9,5	–
3.8	2	Sheet metal screw 3,5 x 13; stainless steel	113.431.04
3.9	4	Sheet metal screw 4,2 x 19; stainless steel	113.431.07
4.1	1	STB 51°C	304.021.02
4.2	1	Nut M10	–
4.3	1	PVC screwed cap	–
5.1	1	Contactora	–
5.2	2	Nut M4	–
5.3	2	Washer	–
5.4	2	Countersunk head screw M4 x 16	–
6.1	1	Control thermostat 0 - 40°C	304.021.03
6.2	2	Countersunk head screw M4 x 4	–
6.3	1	Controller	–
7	1	SDB	391.033.00
8	2	PVC screw connection	–
8.1	1	PVC screw connection	–
8.2	1	PVC screw connection	–
9	2	Plastic holding device	–
9.1	2	Plastic holding device	609.204.75
10	2	stainless steel holding device	304.001.01
11	1	Flow switch	304.001.06
11.1	1	Flow switch	304.001.04



10

EG-Declaration of Conformity

within the sense of the EU guidelines

- Low voltage Norm 2006/95/EG
- EMV- (electromagnetic compatibility) Norm 2004/108/EG

Product **Electric heat exchanger**
Manufacturer **BEHNCKE® GmbH**
Type **EWT 80-40/-41, 80-70/-71, 80-81**
Maschine No.
Year of construction

The Declaration of Conformity was developed, designed and produced, in accordance with the above-mentioned guidelines, by

BEHNCKE® GmbH
Michael-Haslbeck-Str. 13
D-85640 Putzbrunn/München

Applied Standards:

- DIN EN ISO 13732-1 – Temperatures of touchable surfaces
- DIN 55014-1; VDE 0875-14-1 – Interference emission
- DIN 55022; VDE 0878-22 – Methods of measurement of radio disturbance voltage and radio disturbance power
- DIN 60730-2-7; VDE 0631-2-7 – Safety of household and similar electrical appliances
- DIN EN 60947-1; VDE 0660-100 – Low-voltage switching units
- DIN EN 61000-4-6; VDE 0847-4-6 – High - frequency launching immunity test
- DIN EN 60335-2-35; VDE 0700-35 – (Crrigendum: 2012-04)
Household and similar electrical appliances - Safety -
Par 2-35: Particular requirements for instantaneous water heaters
- GSGV - Electrical devices
- DIN EN 61000-4-2 – Electrostatic discharge immunity test
- DIN EN 61000-4-4 – Electrical fast transient/burst immunity test
- DIN EN 61000-4-4 – Power frequency magnetic field immunity test
- DIN EN 61000-4-4 – Pulse magnetic field immunity test
- DIN EN 61010-x – Safety requirements for electrical equipment for measurement, control and laboratory use.

The operating instructions with respect to the product are available
- in the original version English

Putzbrunn

06.03.2013

Christian Ebert, plant Manager

Place

Date

Signing person

Signature